



minipack® - torre

UNEXPECTED IDEAS

Minipack-Torre S.p.A.

Via Provinciale, 54 - 24044 Dalmine (BG) - Italy
Tel.: +39.035563525 - Fax +39.035564945
www.minipack-torre.it - info@minipack-torre.it

UK USA All the information and pictures in this catalog are based on product specifications last updated when it was published. MINIPACK-TORRE S.p.A. reserves the right to modify colors, materials, features and specifications of its models anytime and without notice and is not responsible for possible typing errors. Product specifications are indicative and subject to manufacturer's verification. Some models may be pictured with accessories and/or features not available in some countries. All rights reserved. The reproduction in any way and through any mean is forbidden without the prior authorization of MINIPACK-TORRE S.p.A.



CONCEPT, CREATIVE, ART DIRECTION **BAGAR S.R.L.** PHOTOS **ILARDO TEAM - DIECIBOICI** PRINTED **09.2013**

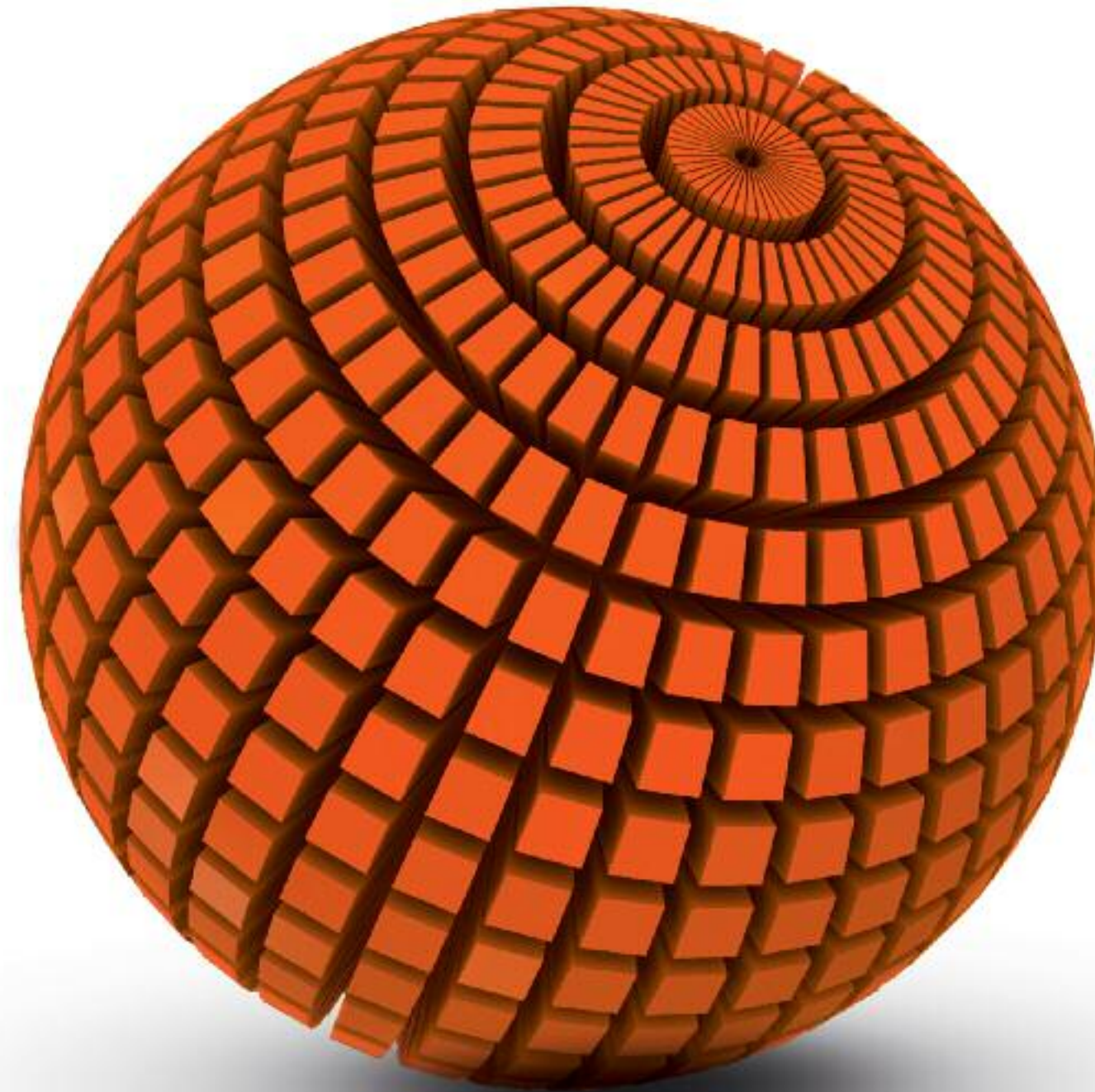

MINIPACK-TORRE 

MINIPACK-TORRE. UNEXPECTED IDEAS

Ten world-wide patented models, four technological advanced production facilities (one completely automated), a world-wide distribution network, a widespread technical assistance, the Certificate of Quality UNI EN ISO 9001:2000: this is what today MINIPACK-TORRE is.

In more than 30 years the company has gained a world-wide leader position in the packaging machines field. Any equipment provided is reliable, ensures a good productivity and always impresses for the great ideas which has.

DESIGN AND PRODUCTION.

We believe that in order to achieve goods results, every single project has to be personally followed from the beginning to the end. At MINIPACK-TORRE all the steps of a project are entirely developed inside the company. That is why a steel-works has been created inside the company to build all the chassis and the whole components of the machines. This gives a great flexibility to the whole structure.

HI-TECH MANUFACTURING PLANTS.

The manufacturing plants are completely automated. The staff is continuously working in order to fulfill any specific and customized requirements from all the customers.

QUALITY POLICY.

The two Certificates of Quality UNI EN ISO 9001-VISION 2000 obtained in the year 2001 represent an important goal and a never-ended engagement to satisfy the customers thanks to a strict quality control procedure in production, commercial services and after-sales assistance.

R&D

Every year 5% of the general turnover is invested in R&D. This continuous research allows MINIPACK-TORRE to always be on the top level of a market which is constantly in evolution. Thanks to the R&D department the company is always able to offer new advanced and reliable packaging systems.

SAFETY: TOP PRIORITY.

More than others, MINIPACK-TORRE has taken into great consideration the safety of the operators of their machines. That is why they deeply and continuously studied and developed new safety systems.

THE ADVANTAGES OF THE AUTOMATIC MACHINES

Automatic machines = to be employed by companies which need high production outputs.

A deeper analysis controverts this idea and underlines the great advantage which derives from the employment of an automatic machine instead of a semi-automatic one.

Also for outputs which are not so high (2500-3000 pcs/day), a considerable cost saving may be obtained, since it is possible:

- to employ labor force (operator) in

other activities for 7/8 months yearly thus keeping the same productivity level.

- to obtain an advantage which derives from energy saving(the tunnel is switched off for the relative period).

- to face any peak in production thus not creating any difficulty in production and any extraordinary work.

Flexibility is another advantage. The automatic machines may be employed in several application fields: food, retail, graphic and mailing, GDO,

industrial and textile.

This why, after two years of intensive work since the creation of the first prototype, MINIPACK-TORRE has introduced the new PRATIKA 56 range, the ultimate turning point of its production.

With the new generation automatic machines there is a 70% saving in labor costs comparing to a semi-automatic machine.



PRATIKA 56 LINE

CREATIVITY BY MINIPACK-TORRE RELIABILITY BY SCHNEIDER ELECTRIC

MINIPACK-TORRE's distinctive feature is its capacity to project, innovate and amaze for the great ideas which embody its products. For its next-generation **PRATIKA 56** automatic machine new range, it has not only chosen cutting edge, not to say revolutionary, mechanical project solutions. Moreover **MINIPACK-TORRE** has also chosen the electronic technology

and the components of a world-wide known trade-mark: **SCHNEIDER ELECTRIC**. The result is a perfect synthesis of reliability, high performances, flexibility and safety which changes the concept of the automatic machine with thermo-shrinking film once again. The future in automatic packaging has already started.

PRATIKA 56

minipac



PRATIKA 56

AUTOMATIC TECHNOLOGY
AT AN AFFORDABLE PRICE.

Basic model of the new **MINIPACK-TORRE** automatic machine line

- L-sealing system
- **SCHNEIDER ELECTRIC** PLC operation control
- Standard kissing-belt
- Pneumatic supply (60 lt/min)

MAXIMUM PRODUCT DIMENSIONS

Height 160mm
Width 400mm x length 600mm

HOURLY OUTPUT

0-2400 pcs/h

EMPLOYED FILMS

Polyolefin, PVC, Polythene
from 7 to 80 micron



PRATIKA 56CS

THE COMPLETENESS
OF CENTER SEALING

The evolution of the new **MINIPACK-TORRE** automatic machine line

- L-sealing system
- Center Sealing device
- **SCHNEIDER ELECTRIC** PLC operation control
- Standard kissing-belt
- Pneumatic supply (60 lt/min)

MAXIMUM PRODUCT DIMENSIONS

Height 240mm
Width 400mm x length 600mm

HOURLY OUTPUT

0-2400 pcs/h

EMPLOYED FILMS

Polyolefin, PVC, Polythene
from 7 to 80 micron



PRATIKA 56MPE

A NEW CONCEPT FOR THE MAXIMUM SPEED
AND FLEXIBILITY

The most appreciated model of the new **MINIPACK-TORRE** automatic machine line

- L-sealing system
- Center Sealing device
- **SCHNEIDER ELECTRIC** PLC brushless servomotor
- **SCHNEIDER ELECTRIC** PLC operation control
- Electric supply (no pneumatic connection is needed)

MAXIMUM PRODUCT DIMENSIONS

Height 240mm
Width 400mm x length 600mm

HOURLY OUTPUT

0-3600 pcs/h

EMPLOYED FILMS

Polyolefin, PVC, OPP, Polythene
from 7 to 80 micron



PRATIKA 56MPS

THE PLUS OF THE SIDE-SEALING

The top model of the new **MINIPACK-TORRE** automatic machine line

- Side sealing system
- Center Sealing device
- **SCHNEIDER ELECTRIC** PLC brushless servomotor
- **SCHNEIDER ELECTRIC** PLC operation control
- Electric supply (no pneumatic connection is needed)

MAXIMUM PRODUCT DIMENSIONS

Height 240mm
Width 400mm x infinite length

HOURLY OUTPUT

0-3000 pcs/h

EMPLOYED FILMS

Polyolefin
from 7 to 80 micron

NEW LINE PRATIKA 56

BEYOND COMPARE

PRODUCTIVITY

- High sealing and product output
- Output up to 60 pcs/min (for Pratika 56MPE) changeable according to the product, the employed film and the operator's ability
- Kissing belt system to pack also small dimensions products



FUNCTIONALITY

- Rear movable roll loading
- Film stretch adjustment weights
- High technology vertical photocell
- Electronic counter cycles
- Automatic control of the switch-on functions

VERSATILITY

- Maximum product width:400mm. Maximum product length: 600mm
- Infinite length product packaging on 56MPS
- Maximum product height 240mm (Pratika 56CS/56MPE/56MPS) and 160mm (Pratika 56)

USER-FRIENDLY

- Lighted working area
- Machines on adjustable locking casters
- Level bubble
- Frontal and rear opening for easy access and intervention on the machine
- Customized using procedures operator/assistant

SAFETY

- Machine completely closed by a covering, even on the in-feed/out-feed belts and roll support
- Safety micros on the access doors of the machine
- Operation control with operator safety
- Visible and acoustic alarm signal of the machine stop

The new **PRATIKA 56** line is born, not only from the proven **MINIPACK-TORRE** "power of ideas", but also from a deep attention to the market needs which has always been in search for a product which must be both highly technological but flexible and "user-friendly". The range is composed of 4 models with common highly technological and reliable equipments, which have specific features to meet different and specific packaging needs. "Made in Italy with an international heart": **PRATIKA 56** models are entirely produced at **MINIPACK-TORRE** production facilities but the heart of electric and electronic components of a multinational company like **SCHNEIDER ELECTRIC** is beating inside them.

VISIBLE AND ACOUSTIC
ALARM SIGNAL

INTERNAL LIGHT

SLIDING DOOR

IN-FEED AND OUT-FEED BELT
COMPLETE COVERING

FRONTAL CONTROL PANEL
WITH EASY ACCESS AND SAFETY KEY

NEW DESIGN
BODY WORK

TECHNICAL FEATURES

Schneider Electric PLC operation control with 256 customizable and namable programs

8-language touch-screen display with USB door

Information to the operator of the roll and the opening film roll position depending on the product (Pratika56MPE/56MPS)

New micro-puncher kit with adjustable tensioning film

Center Sealing device, adjustable on the product height set-up (Pratika 56CS/56MPE/56MPS)

New sealing bar activating frame which balances the pushes thus making the movement more fluid

Motorized adjustable height of the triangles on product height set-up (Pratika 56/56CS)

Auto set-up of the height of the triangles and bars related to the height of the product (Pratika56MPE/56MPS)

Sealing bar opening directly set-up on the touch screen control panel (Pratika56MPE/56MPS)

Speed belts adjustable by inverter (in-feed / out-feed belt)

In-feed and out-feed electronic port to interface additional in-feed and out-feed belts

Standard conveyors in compliance with food regulations in force (FDA) and fully anti-static

Motorized waste film winder

Full waste film winder alarm device

Possibility to combine with shrinking tunnel

40 CM ENTRY
SUPPORT SPACE

WASTE-WINDER
MOTOR

FILM STRETCH
ADJUSTMENT
WEIGHTS

PRODUCT ENTRY WITH SIMPLE
WIDTH ADJUSTING

FILM ROLL DRAWER
WITH SAFETY REAR SLIDING DOOR

MACHINE ON
ADJUSTABLE CASTERS

FULL WASTE
WINDER ALARM DEVICE

ELECTRIC PANEL
WITH SCHNEIDER ELECTRIC COMPONENTS



STANDARD COMPONENTS

- All the wiring converges into the electric panel with an easy access for ordinary maintenance

PHOTOCELLS

- 2 product reading photocells
- Printed film photocell
- End roll and end film photocell
- Product entry photocell
- Full waste film winder photocell

THE MOST ADVANCED SERVO-ASSISTANCE IN MOVEMENT FOR:

- Power and high performances
- Compactness and strength
- Energy efficiency
- User-friendliness and easy maintenance
- Safety
- World-wide assistance

SERVO DRIVE & SERVO MOTOR

- Lexium 32A starter, equipped with "Safe Torque Off" (IEC / EN 61800-5-2) safety function
- Low inertia brushless series BSH servo-motor studied for highly dynamic applications

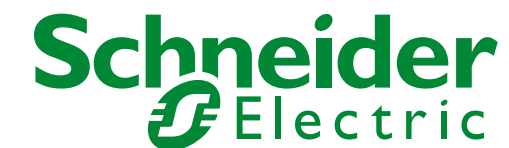

PROGRAMMABLE LOGIC CONTROLLER (PLC)

- Reliable and strong computer for industrial production management
- Touch-screen control panel
- Easy to be used 8-language display
- USB door for any software updating and maintenance operation
- Possibility to set-up 256 customizable and namable programs



WELCOME ON BOARD WITH SCHNEIDER ELECTRIC TECHNOLOGY

A PROMINENT PARTNER

As a global specialist in energy management with operations in more than 100 countries, **SCHNEIDER ELECTRIC** offers integrated solutions across multiple market segments, including leadership positions in energy and infrastructure, industrial processes, building automation, and data centres/networks.

The world-wide presence of **SCHNEIDER ELECTRIC** means reliability. A high level professional distribution network providing products, spare parts, components and assistance is spread throughout all the 5 continents.

The choice of a **MINIPACK TORRE - SCHNEIDER ELECTRIC** partnership is a guarantee for **MINIPACK TORRE** machine users, since they can rely upon highly technological and up-dated products and upon an efficient assistance which provides time and costs saving in service.

www.schneider-electric.com

INNOVATION BRINGS CONCRETE ADVANTAGES



CENTER SEALING

WHAT IS IT FOR

Sealing system which allows the horizontal film sealing in the middle of the product

ADVANTAGES

Aesthetically perfect packages and high quality sealing with any type of film



SIDE SEALING SYSTEM

WHAT IS IT FOR

It substitutes the classic L-sealing system

ADVANTAGES

It is suitable for long products packaging: sealing area 400 mm x infinite (height up to 240 mm)



ELECTRIC POWER SUPPLY ONLY

WHAT IS IT FOR

No pneumatic connection is needed for the machine

ADVANTAGES

Less maintenance, less noise, more energy saving



BRUSHLESS MOTOR WITH SERVO-MOTOR (Schneider Electric)

WHAT IS IT FOR

It substitutes the pneumatic movement of the sealing unit

ADVANTAGES

Comparing to the pneumatic supply it guarantees a more precise film sealing and a high output (up to 60 pcs /min)



SELF-ADJUSTMENT

WHAT IS IT FOR

To auto set-up the height of the triangles and the sealing bar in relation to the product height

ADVANTAGES

The parameters selection without the operator action makes the set-up more precise and easier in any machine start-up



KISSING BELT SYSTEM

WHAT IS IT FOR

To adjust the belts distance upon the sealing parameters set-up.

ADVANTAGES

It allows to package easily also small size products

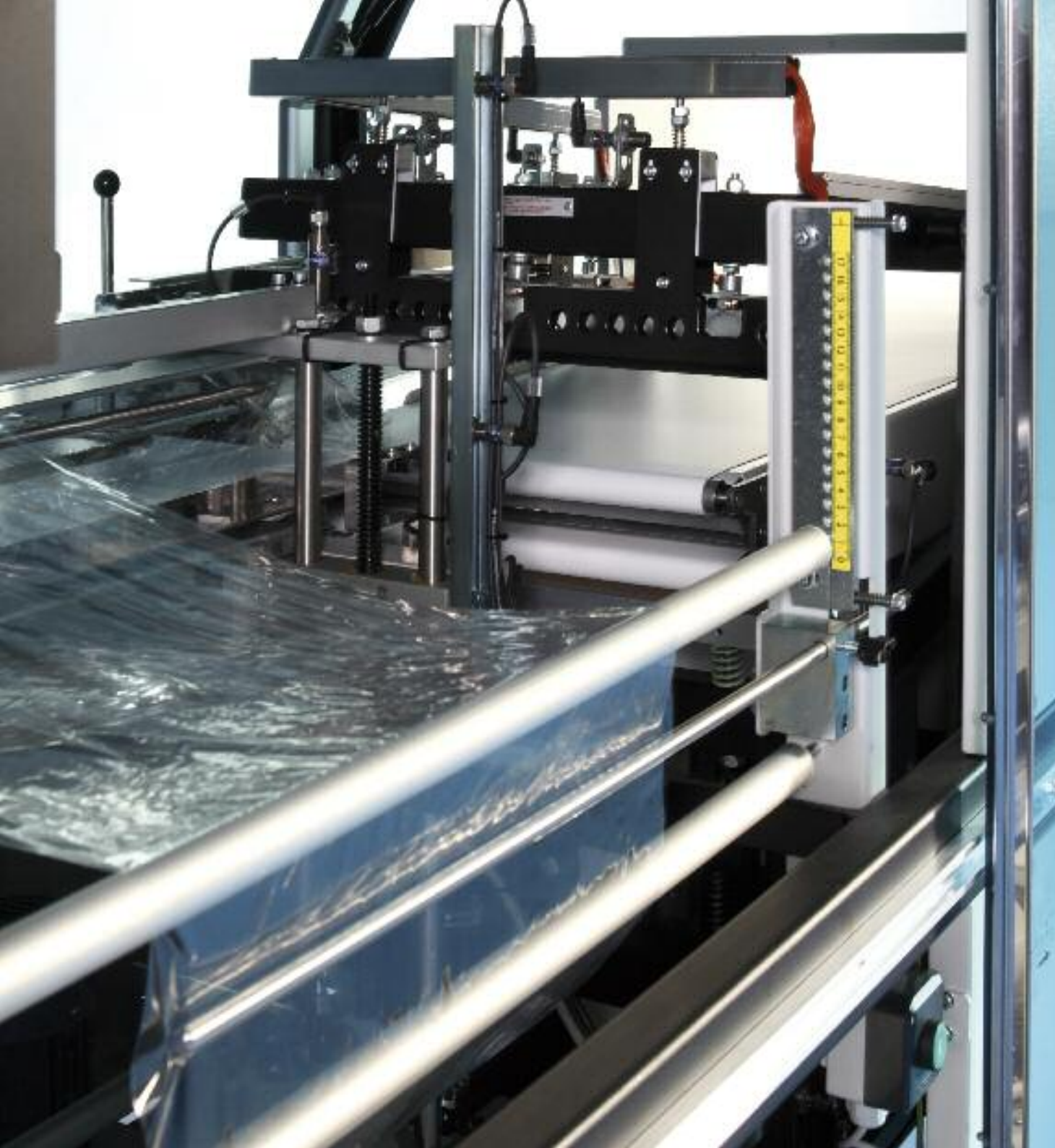

OPTIONAL

Kissing belts *
Printed film photocell
End film and end film roll photocell
Photocell reading the product on the in-feed conveyor
Pressure adjuster **
Film perforator
Pedal control
Possibility to combine with shrinking tunnel

* PRATIKA 56 MPE - 56 MPS

** PRATIKA 56 - 56 CS

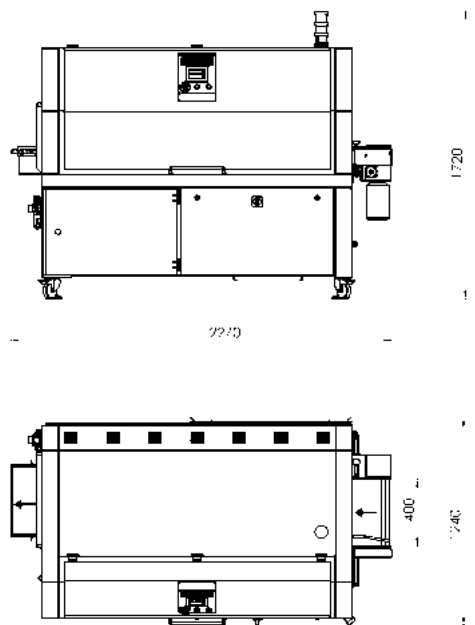

TECHNICAL DATA

		PRATIKA 56	PRATIKA 56 CS	PRATIKA 56 MPE	PRATIKA 56 MPS
Power supply	V	230 1 Ph	230 1 Ph	230 1 Ph	230 1 Ph
Supply		pneumatic	pneumatic	only electric power supply	only electric power supply
Max. power	Kw	2,5	2,5	3	3
Output per hour	pz/h	0-2400	0-2400	0-3600	0-3000
Sealing bars dimensions	mm	600 x 400	600 x 400	600 x 400	unlimited x 400
Max. film roll dimensions	mm	Ø300 x 700	Ø300 x 700	Ø300 x 700	Ø300 x 700
Max. product dimensions	mm	400x160x lenght 600	400x240x lenght 600	400x240x lenght 600	400x240x lenght unlimited
In-feed belt height	mm	870	870	870	870
Machine dimensions (with open hood)	mm	2485 x 1245 h. 1900	2485 x 1245 h. 1900	2485 x 1245 h. 1900	2485 x 1245 h. 1900
Machine dimensions (with closed hood)	mm	2485 x 1245 h. 1715	2485 x 1245 h. 1715	2485 x 1245 h. 1715	2485 x 1245 h. 1715
Packed machine dimensions	mm	2940 x 1440 h. 1985	2940 x 1440 h. 1985	2940 x 1440 h. 1985	2940 x 1440 h. 1985
Machine weight (net/gross)	Kg	671/721	724/774	763/813	763/813

FEATURES

		PRATIKA 56	PRATIKA 56 CS	PRATIKA 56 MPE	PRATIKA 56 MPS
Center Sealing		not available	standard	standard	standard
Kissing Belt		standard	standard	optional	optional
PLC Schneider Electric with touch screen display with 256 customisable programs		standard	standard	standard	standard
Pneumatic supply		60 lt/min	60 lt/min	no	no
Electric power supply		no	no	yes	yes
Sealing System		L-sealing	L-sealing	L-sealing	Side sealing
Packages height	mm	from 0 to 160	from 0 to 240	from 0 to 240	from 0 to 240



TUNNEL 50



TUNNEL 50 TWIN



TUNNEL 70

TUNNEL 50 TUNNEL 50 INOX TUNNEL 50 TWIN TUNNEL 70

**FLEXIBLE AND
UPDATED SOLUTIONS
TO GET THE BEST
PACKAGING**

TECHNICAL DATA

		TUNNEL 50 / 50 INOX	TUNNEL 50 TWIN	TUNNEL 70
Power supply	V	200/208/220/380/415/440	200/208/220/380/415	200/208/220/380
Power max.	Kw	7	14	14
Conveyor speed	m/min	1 2 5 12	2 10 24	1 5 12
Max product dimensions	mm in	380x220 lg.740 14.96x8.66 lg. 29.13	380x190 lg.1140 14.96x8.22 lg.44.88	500x350 lg.1200 19.69x13.78 lg47.25
In-feed working belt height	mm in	850/880 33.46/34.64	850/880 33.46/34.64	845/875 33.27/34.45
Out-feed working belt height	mm in	850 33.46	850 33.46	845 33.27
Machine dimensions	mm in	1770x840 h.1465 64,16x33.06 h.57.67	2130x800 h.1460 83,85x31.50 h.57.47	2770x1160 h.1640 109,04x45.66 h.64.57
Packed machine dimensions	mm in	1390x910 h.1640 54,72x35,82 h.64.57	1930x980 h.1745 75.98x38.58 h.68.70	2030x1230 h.1830 79.92x48.43 h.72
Machine weight (net/gross)	Kg pound	188/228 414/502	260/318 572/700	415/483 913/1063
Tunnel entrance dimension	mm in	450x240 17.71x9.45	450x210 17.71x8.26	690x390 27.16x15.35

FEATURES

- Manual regulation of conveyor height
- Digital display with 9 storable programs
- Selection of self rotation of conveyors rolls
- Double air flap
- Auto switch-off
- Exit roll conveyor
- Two independent heating rooms

OPTIONAL

- Plexiglas thermal protections at the inlet and outlet of the tunnel
- Teflon belt
- Metal belt

